

# IGNITION AND FLAME DETECTION ELECTRODES

## RS series

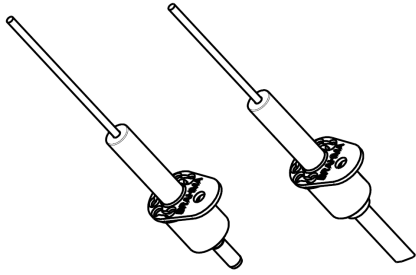

## RC series

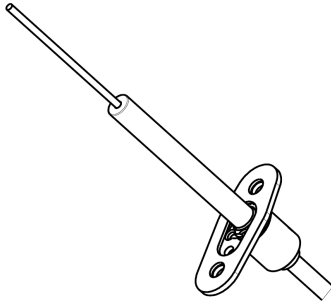

## AC series

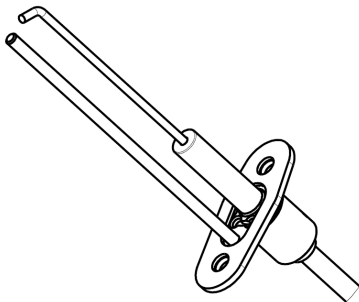

## SALV series

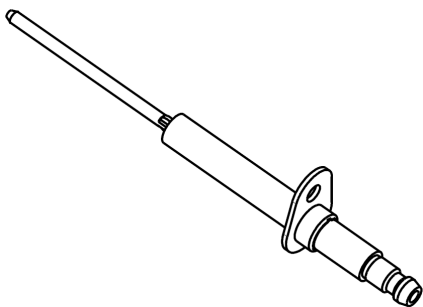

## ALV series

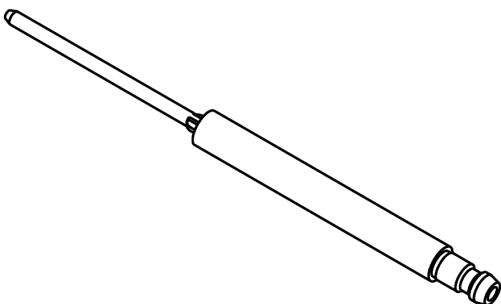

### DESCRIPTION

The characteristics and the type of materials used to manufacture these electrodes make them suitable for use as ignition electrodes in general, but also as flame sensors in gas burners (the **SALV** and **ALV** series can be used in applications where the temperature can be close to 300°C).

Their use as flame detection electrodes is based on the electrical conductivity of the flame, as well as on the fact that a substantial difference between the electrode mass in contact with the flame and the burner mass enables the current to flow mainly from the electrode to the burner housing. In order to obtain a good flame signal, the burner housing should be well connected to earth.

The generated current, usually amounting to some  $\mu\text{A}$ , depends on the electrode-mass-to-burner-mass ratio, on the position of the electrode in relation to the flame and on the combustion quality.

Warning: make sure the detection electrode is placed at a suitable distance from the ignition electrode, in order to prevent the electrical discharges produced during burner ignition from striking the ground through the detection electrode, thus damaging the connected flame detection device.

### FEATURES

RS, RC and AC series

The electrodes of these series consist of a Kanthal metal rod, a glazed alumina insulating part, a galvanized iron fixing bracket and a casing made of high-temperature resistant thermoplastic material.

The electrical wiring is carried out by means of  $\varnothing$  4 mm and  $\varnothing$  6,35 mm terminals or by a  $\varnothing$  5mm high-insulation silicone cable.

The thermoplastic casing, placed on the back of the electrode, enables to get extremely interesting advantages, such as:

- excellent insulation between the ceramic and the fixing bracket;
- high tensile and torsional strength;
- high vibration and impact strength.

These electrodes have been developed for application in condensing wall-hung boilers, in particular the RC series as flame detection electrode and the AC series as double-rod ignition electrode. Since they have to be perfectly sealed, they are supplied with gaskets.

### SALV series

The electrodes of this series consist of a kanthal metal rod (flame detection electrodes) or an AISI steel rod (ignition electrodes), a glazed alumina insulating part and a galvanized iron fixing bracket.

The electrical connection occurs by means of terminals diam. 6,35 mm.

These electrodes enable to get some advantages as described below:

- resistance in high-temperature rooms ( $< 350^\circ\text{C}$ );
- excellent insulation between the ceramic and the fixing bracket;
- excellent insulation between the fixing bracket and the connection terminals;
- high tensile and torsional strength.

### ALV series

The electrodes of this series consist of a kanthal metal rod (flame detection electrodes) or an AISI steel rod (ignition electrodes) and a glazed alumina insulating part.

The electrical connection occurs by means of terminals diameter 6,35 mm.

These electrodes can be used in rooms with high temperatures  $< 350^\circ\text{C}$ .

The electrodes consist of the following parts:

**Ceramic**

- Glazed alumina with diameter 6 mm (ALV series)
- Glazed alumina with diameter 7 mm (RS, RC and AC series)
- Glazed alumina with diameter 8 mm (SALV and ALV series)
- Glazed alumina with diameter 10 mm (SALV and ALV series)
- Glazed alumina with diameter 11 mm (ALV series)
- Glazed alumina with diameter 14 mm (ALV series)

**Bracket**

- Galvanized iron (RS, RC, AC and SALV series)

**Rod**

- Kanthal A1 with diameter 2 mm (RS, RC and AC series)
- Kanthal A1 with diameter 2,5 / 3 mm (SALV and ALV series)
- AISI steel with diameter 2,5 / 3 mm (SALV and ALV series)

**Standard connection terminals**

- Cylindrical terminals diameter 4 mm (RS, RC and AC series)
- Cylindrical term. diameter 6,35 mm (RS, RC, AC, SALV and ALV series)
- Silicone cable diameter 5 mm (RS, RC and AC series)  
*electrical insulation 24 kV*

**Max. operating temperature**

- RS, RC and AC series** 270° C
- SALV and ALV series** 350° C

Standard Brahma dimensions and/or characteristics are shown in Table .1, Table .2 and Table .3.

**OVERALL DIMENSIONS**

Figures 1, 2, 3, 4 and 5 show examples of the main fixed and variable overall dimensions of the electrodes, while Figures 6 and 7 show the available standard fixing brackets. The bracket shown in Figure 8 is not a standard and is therefore available on request only.

- **RS...T...** series electrode with cylindrical terminal

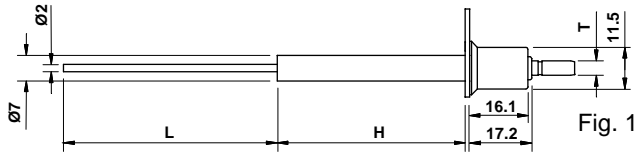

- **RS...C...** series electrode with silicone cable

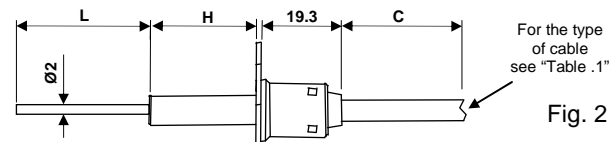

- **RC/AC...C...** series electrode with silicone cable

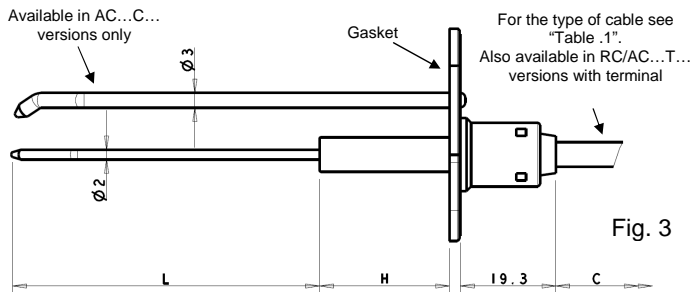

- **SALV series** electrode with cylindrical terminal

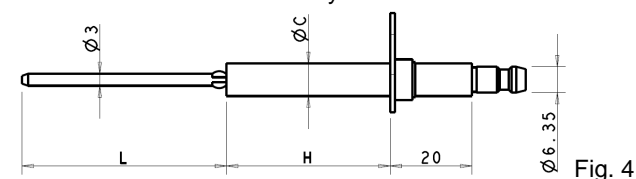

- **ALV series** electrode with cylindrical terminal

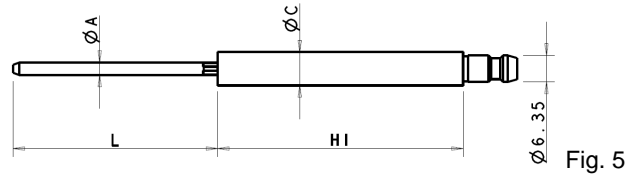

**Key** (Figures 1, 2, 3 and 4):

- H** = Ceramic length starting from the bracket (figures 1, 2, 3, 4);
- H1** = Ceramic length (figure 5);
- ØC** = Ceramic diameter (figures 4 and 5);
- L** = Rod length out of the ceramic (figures 1, 2, 3, 4 and 5);
- ØA** = Rod diameter (figure 5);
- T / M** = Type of terminal (figures 1, 2 and 3);
- C** = Silicone cable length (figures 2 and 3);

- Bracket with 10 mm centre distance (electrodes type **RS...T/C...** and **SALV...**)

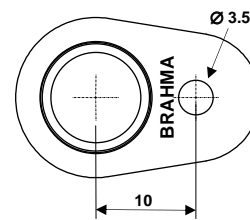

- Two-hole bracket with 10 and 18 mm centre distances (electrodes type **RC...T/C...** and **AC...T/C...**)

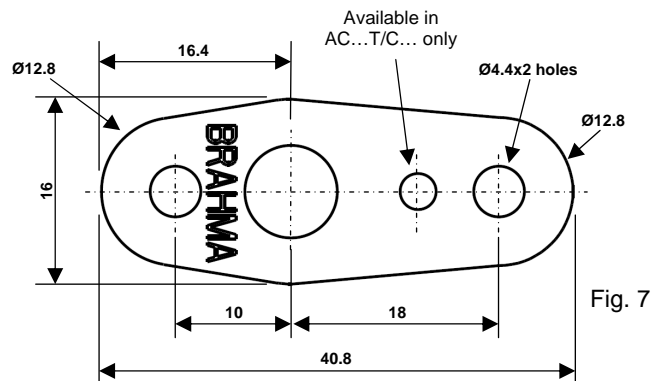

- Bracket with slot with 11,7 ÷ 18,2 mm centre distance available on request (electrodes type **RB...T/C...**).

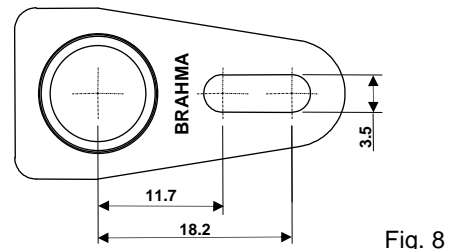

## MANUFACTURING FEATURES

Table .1 (**RS, RC** and **AC** series), Table .2 (**SALV** series) and Table .3 (**ALV** series) show the possible solutions for the connection of the electrodes to an ignition transformer or to a board, and are a key to electrode designations.

### ELECTRODES TYPE $X_1X_2X_3$ $X_4$ $X_5/X_6$

|  |   |
|--|---|
| $X_1=$   | <b>RS:</b> (standard) fixing bracket with 10 mm centre distance (see Fig. 6)  |
|  | <b>RB:</b> Fixing bracket (no standard model, available on request only) with 11,7 ÷ 18,2 mm centre distance (see Fig. 8) |
|  | <b>RC:</b> Two-hole fixing bracket (see Fig. 7)   |
|  | <b>AC:</b> Two-hole / two-rod fixing bracket (see Fig. 7)   |
| $X_2=$   | <b>27:</b> Ceramic length from the bracket 27 mm (H see Fig. 1-2-3)   |
|  | <b>58:</b> Ceramic length from the bracket 58 mm (H see Fig. 1-2-3)   |
|  | <b>67:</b> Ceramic length from the bracket 67 mm (H see Fig. 1-2-3)   |
| $X_3=$   | Finishing at the opposite end to the rod (electrical connection)  |
|  | <b>C:</b> (standard) $\varnothing$ 5 mm silicone cable (C see Fig. 2-3)   |
|  | <b>T4:</b> (standard) $\varnothing$ 4 mm terminal (T see Fig. 1-3)  |
|  | <b>T6:</b> (standard) $\varnothing$ 6,35 mm terminal (T see Fig. 1-3)   |
|  | <b>M4:</b> M4 threaded terminal (T see Fig.1-3) - no standard model   |
| $X_4=$   | Length of the straight rod out of the ceramic in mm (L see Fig.1-2-3)   |
|  | <b>P:</b> Bent rod out of the ceramic (to customer's drawing)   |
| $X_5=$   | Silicone cable length in mm (C see Fig. 2-3)  |
| <b>In RXXXC and AXXXC versions (electrodes with cable)</b> |   |
| $X_6=$   | Possible finishing / protections for silicone cable on connection side  |
|  | <b>TGL:</b> Cut cable (no cable jacket / insulation stripping)  |
|  | <b>Z:</b> Stripped cable  |
|  | <b>2:</b> 2,8x0,5 mm female fast-on terminal  |
|  | <b>4:</b> $\varnothing$ 4 mm terminal   |
|  | <b>6:</b> 6,35x0,8 mm female fast-on terminal   |
|  | <b>8:</b> 4,8x0,8 mm female fast-on terminal  |
|  | <b>PG5:</b> Rubber protection for $\varnothing$ 4 terminals (see Fig. 9)  |
|  | <b>PS4:</b> $\varnothing$ 4 silicone protection for $\varnothing$ 4 terminals (see Fig. 10)                               |
|  | <b>TRM:</b> Heat-shrink tube protection for female fast-on terminals (see Fig. 11)  |

Table .1

For example, the designation "**ELECTRODE TYPE RS27C 50 300/2 TRM**" (see Table .1) refers to an electrode manufactured as follows:

- Electrode with standard fixing bracket with 10 mm centre distance **RS**
- Ceramic length starting from the bracket 27 mm **27**
- Finishing at the opposite end to the rod, silicone cable **C**
- 50 mm straight rod out of the ceramic **50**
- 300 mm cable out of the electrode **300**
- Cable equipped with 2,8x0,5 female fast-on **2**
- Heat-shrink tube fast-on terminal protection **TRM**

- Rubber protection for  $\varnothing$  4 terminals (**PG5**), for electrodes type **RSxxC**;

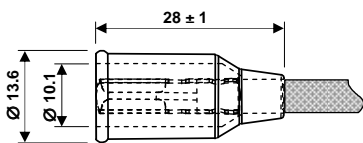

Fig. 9

- Gasket for **RC** and **AC** electrodes

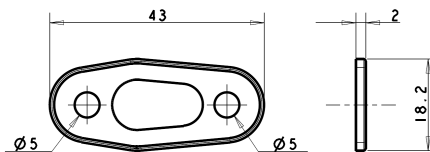

Fig. 12

- Silicone protection for  $\varnothing$  4 terminals (**PS4**), for electrodes type **RSxxC**;

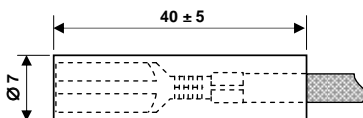

Fig. 10

- Heat-shrink tube protection for female fast-on terminals and  $\varnothing$  4 terminals (**TRM**), for electrodes type **RSxxC**;

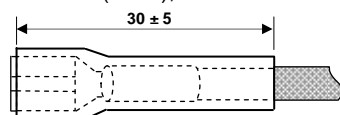

Fig. 11

Electrodes type **RC...T/C...** and **AC...T/C...** are always provided with gasket (Fig. 12).

**ELECTRODES TYPE X<sub>1</sub> X<sub>2</sub> SALV X<sub>3</sub> X<sub>4</sub>**

|                       |   |
|-----------------------|---|
| <b>X<sub>1</sub>=</b> | <b>DET.:</b> Flame Detection Electrode  |
|                       | <b>IGN.:</b> Ignition Electrode   |
| <b>X<sub>2</sub>=</b> | <b>K3,0:</b> KANTHAL rod Ø 3 mm   |
|                       | <b>A3,0:</b> AISI STEEL rod Ø 3 mm  |
| <b>SALV=</b>          | Glazed alumina ceramic with fixing bracket with 10 mm centre distance (see Fig. 6)      |
| <b>X<sub>3</sub>=</b> | <b>8..60:</b> Ceramic length from the bracket 40 mm with Ø 8 mm (H - ØC see Fig. 4)     |
|                       | <b>8..80:</b> Ceramic length from the bracket 60 mm with Ø 8 mm (H - ØC see Fig. 4)     |
|                       | <b>8..120:</b> Ceramic length from the bracket 100 mm with Ø 8 mm (H - ØC see Fig. 4)   |
|                       | <b>10..84:</b> Ceramic length from the bracket 64 mm with Ø 10 mm (H - ØC see Fig. 4)   |
|                       | <b>10..120:</b> Ceramic length from the bracket 100 mm with Ø 10 mm (H - ØC see Fig. 4) |
| <b>X<sub>4</sub>=</b> | Length of the straight rod out of the ceramic in mm (L see Fig. 4)                      |
| <b>P:</b>             | Bent rod out of the ceramic (to customer's drawing)                                     |

**Table .2**

For example, the designation “**DET. ELECTR. K3,0 SALV 8..60.140**” (see Table .2) refers to an electrode manufactured as follows:

|   |              |
|---|--------------|
| - Flame Detection Electrode   | <b>DET.</b>  |
| - KANTHAL rod Ø 3 mm  | <b>K3,0</b>  |
| - Electrode with glazed alumina ceramic, standard fixing bracket with 10 mm centre distance | <b>SALV</b>  |
| - Ceramic length from the bracket 40 mm with Ø 8 mm (ceramic Ø 8 mm and 60 mm length)       | <b>8..60</b> |
| - 140 mm straight rod out of the ceramic  | <b>140</b>   |

**ELECTRODES TYPE X<sub>1</sub> X<sub>2</sub> ALV X<sub>3</sub> X<sub>4</sub>**

|                       |  |
|-----------------------|--|
| <b>X<sub>1</sub>=</b> | <b>DET.:</b> Flame Detection Electrode   |
|                       | <b>IGN.:</b> Ignition Electrode  |
| <b>X<sub>2</sub>=</b> | <b>K2,5:</b> KANTHAL rod Ø 2,5 mm (ØA see Fig. 5)                                      |
|                       | <b>A2,5:</b> AISI STEEL rod Ø 2,5 mm (ØA see Fig. 5)                                   |
|                       | <b>K3,0:</b> KANTHAL rod Ø 3 mm (ØA see Fig. 5)  |
|                       | <b>A3,0:</b> AISI STEEL rod Ø 3 mm (ØA see Fig. 5)                                     |
| <b>ALV=</b>           | Glazed alumina ceramic without fixing bracket (see Fig. 5)                             |
| <b>X<sub>3</sub>=</b> | <b>6..55:</b> Ceramic Ø 6 mm and 55 mm length for rods Ø 2,5 mm (ØC - H1 see Fig. 5)   |
|                       | <b>8..60:</b> Ceramic Ø 8 mm and 60 mm length for rods Ø 3 mm (ØC - H1 see Fig. 5)     |
|                       | <b>8..80:</b> Ceramic Ø 8 mm and 80 mm length for rods Ø 3 mm (ØC - H1 see Fig. 5)     |
|                       | <b>8..120:</b> Ceramic Ø 8 mm and 120 mm length for rods Ø 3 mm (ØC - H1 see Fig. 5)   |
|                       | <b>10..84:</b> Ceramic Ø 10 mm and 84 mm length for rods Ø 3 mm (ØC - H1 see Fig. 5)   |
|                       | <b>10..120:</b> Ceramic Ø 10 mm and 120 mm length for rods Ø 3 mm (ØC - H1 see Fig. 5) |
|                       | <b>11..50:</b> Ceramic Ø 11 mm and 50 mm length for rods Ø 3 mm (ØC - H1 see Fig. 5)   |
|                       | <b>11..67:</b> Ceramic Ø 11 mm and 67 mm length for rods Ø 3 mm (ØC - H1 see Fig. 5)   |
|                       | <b>11..102:</b> Ceramic Ø 11 mm and 102 mm length for rods Ø 3 mm (ØC - H1 see Fig. 5) |
|                       | <b>14..67:</b> Ceramic Ø 14 mm and 67 mm length for rods Ø 3 mm (ØC - H1 see Fig. 5)   |
|                       | <b>14..102:</b> Ceramic Ø 14 mm and 102 mm length for rods Ø 3 mm (ØC - H1 see Fig. 5) |
|                       | <b>14..120:</b> Ceramic Ø 14 mm and 120 mm length for rods Ø 3 mm (ØC - H1 see Fig. 5) |
|                       | <b>14..152:</b> Ceramic Ø 14 mm and 152 mm length for rods Ø 3 mm (ØC - H1 see Fig. 5) |
|                       | <b>14..230:</b> Ceramic Ø 14 mm and 230 mm length for rods Ø 3 mm (ØC - H1 see Fig. 5) |
|                       | <b>14..350:</b> Ceramic Ø 14 mm and 350 mm length for rods Ø 3 mm (ØC - H1 see Fig. 5) |
| <b>X<sub>4</sub>=</b> | Length of the straight rod out of the ceramic in mm (L see Fig. 5)                     |
| <b>P:</b>             | Bent rod out of the ceramic (to customer's drawing)                                    |

**Table .3**

For example, the designation “**DET. ELECTR. K3,0 ALV 8..60.140**” (see Table .3) refers to an electrode manufactured as follows:

|  |              |
|--|--------------|
| - Flame Detection Electrode                                    | <b>DET.</b>  |
| - KANTHAL rod Ø 3 mm   | <b>K3,0</b>  |
| - Electrode with glazed alumina ceramic without fixing bracket | <b>ALV</b>   |
| - Ceramic Ø 8 mm and 60 mm length                              | <b>8..60</b> |
| - 140 mm straight rod out of the ceramic                       | <b>140</b>   |

**Note:** The “SALV” and “ALV” series electrodes with a particularly long rod can be supplied on demand with 2 or 3 ceramics.

**ACCESSORIES**

In case the electrodes are used for ignition, a resistor may be necessary to reduce electromagnetic interference. In this case we recommend using electrodes with “**T**” terminal (Fig. 1 and 4), to be coupled to high voltage cables available with straight connection (PD series) or with 90° connection (PC series) and provided with 1 kΩ, 2,7 kΩ or 4,7 kΩ resistors. For more detailed information see the data sheets of PC./PD... cables.

**ATTENTION -> Company Brahma S.p.A. takes no responsibility for any damage resulting from Customer tampering with the product.**

**BRAHMA S.p.A.**

Via del Pontiere, 31  
37045 Legnago (VR) – ITALY  
Tel. +39 0442 635211 – Fax +39 0442 25683  
http://www.brahma.it  
E-mail: brahma@brahma.it

2014/02/19 Subject to amendments without notice